

SPECIFICATIONS

- FRAME: 1" X 1" AND 3/4" X 3/4" 16GA G90 GALVANIZED SQUARE TUBING
- FILTER CHANNEL: 1" X 1.25" X 1" 16GA G90
- CONSTRUCTION: MIG WELDED .032 E71T-GS A5.20
- HEIGHT: 18" TOP OF TAB / 17" TOP OF CHANNEL / 17.25" WITH CAP
- WIDTH: 17" - 26.5" ADJUSTABLE
- DEPTH: 22"
- SHIPPED FLAT PACKED
- ASSEMBLES IN SECONDS
- PLASTIC CAPS INCLUDED

FLAT PACKAGING

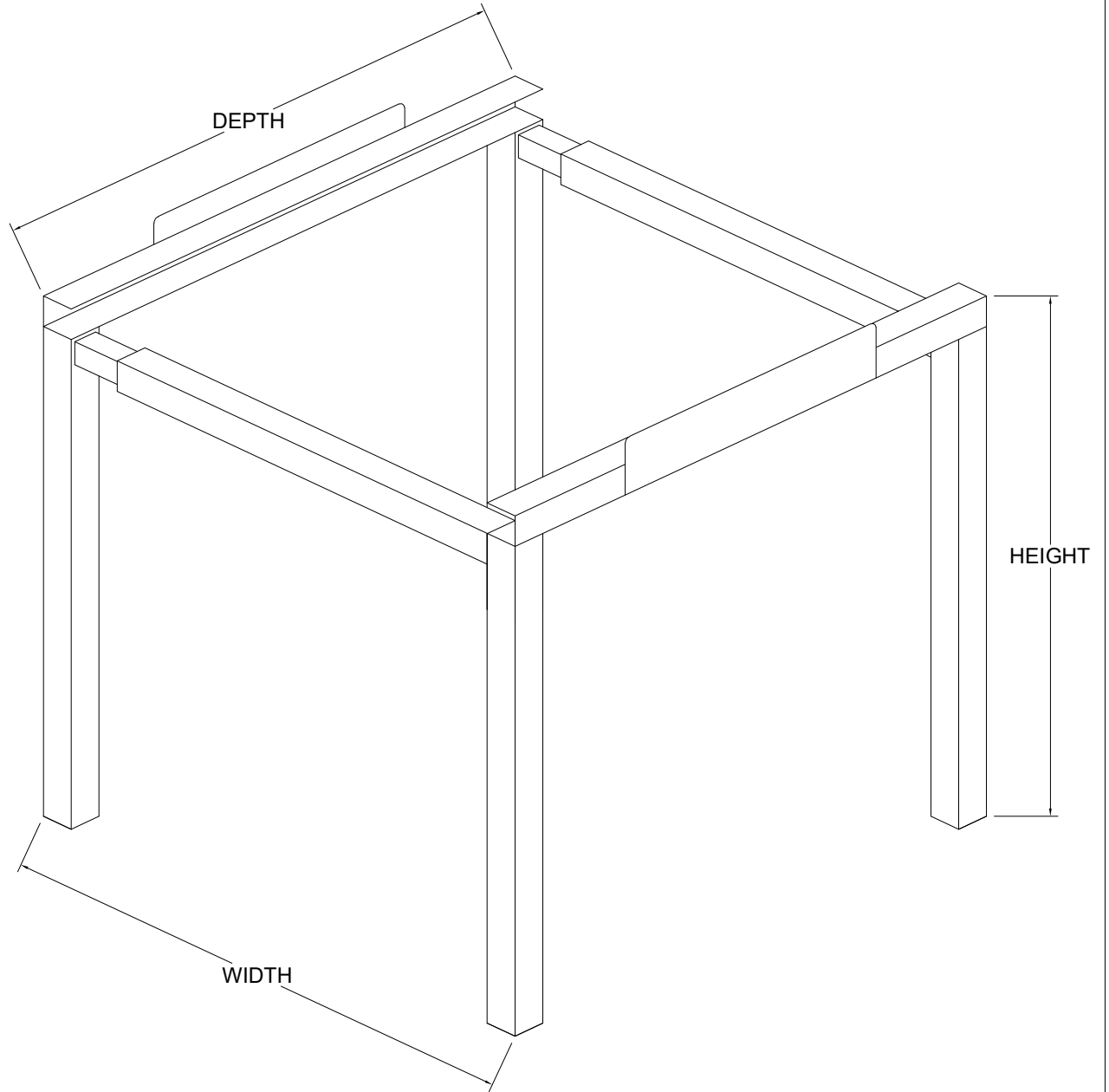
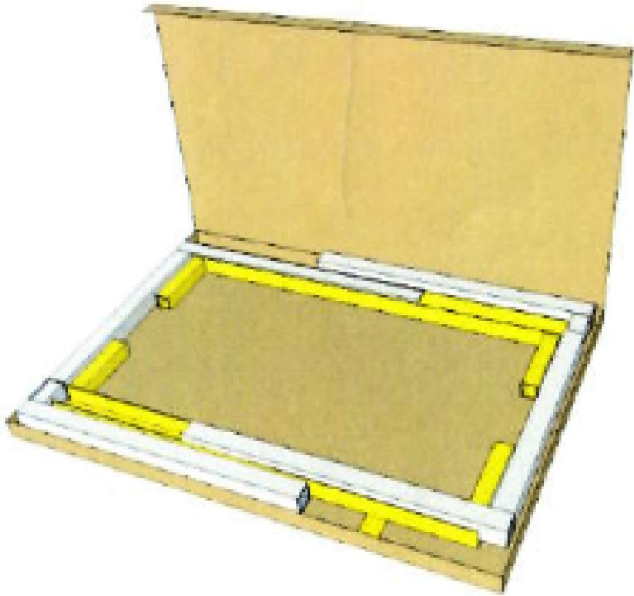

Customer:	*	Subject:	
Contact:	*		
Job Name:	*		
Estimate #:	*		

Adjustable Air Handler Stand - Boxed
32-ADJ18

DWG: RSE	N.T.S.	Not for Shop Drawings	Date: *	Drawing: 1	Revision: 0
----------	--------	-----------------------	---------	------------	-------------